

LITERATURE CITED

1. P. M. Mednis and V. M. Fain, "Excitation of avalanche ionization in transparent dielectrics by a strong ac electromagnetic field," *Zh. Eksp. Teor. Fiz.*, **62**, No. 2 (1972).
2. The Action of Laser Radiation [Russian translation], Mir, Moscow (1968),
3. I. V. Aleshin, S. I. Anisimov, A. M. Bonch-Burevich, Ya. A. Imas, and E. L. Komolov, "Optical breakdown of transparent media containing microinhomogeneities," *Zh. Eksp. Teor. Fiz.*, **70**, No. 4.
4. R. W. Hopper and D. R. Uhlmann, "Mechanism of inclusion damage in laser glasses," *J. Appl. Phys.*, **41**, No. 10 (1970).
5. H. S. Bennett, "Absorption centres in laser materials," *J. Appl. Phys.*, **42**, No. 2 (1971).
6. B. Welber, M. Cardona, C. K. Kim, and S. Rodriguez, "Dependence of the direct gap of GaAs on hydrostatic pressure," *Phys. Rev. B, Solid State*, **12**, No. 12 (1975).
7. L. D. Landau and E. M. Lifshits, *Theory of Elasticity* [in Russian], Nauka, Moscow (1965).
8. A. M. Bonch-Burevich, Ya. A. Imas, M. N. Libenson, V. S. Salyadinov, G. D. Shandybina, and E. B. Yakovlev, "Clarification and shadow waves in silicon induced by multimode laser radiation," *Zh. Tekh. Fiz.*, **47**, No. 3 (1977).
9. Yu. I. Lysnikov and I. A. Shamsutdinov, "Anomalous behavior of light flux intensity in a medium with two types of absorption," *Zh. Prikl. Mekh. Tekh. Fiz.*, No. 4 (1976).

INDUCTANCE OF A SINGLE-COIL MAGNETIC COURSE GENERATOR WITH A VARIABLE GENERATING COIL

V. S. Fomenko

UDC 538.4+621.3.072.3

1. Several types of explosive magnetic generators are known at the present time [1]. Of these (according to published experimental data) the most effective are the coaxial [2], plane-parallel "busbar-busbar" type [3, 4], and the "bellows" type [5]. A high magnetic-flux storage factor of $\eta \sim 80\%$ is achieved in these generators due to the linear increase in the transverse cross section of the current-carrying conductors (busbars) in a region adjacent to the inductive load.

The initial inductance L_0 of plane-parallel explosive magnetic generators depends on the geometrical dimensions of the current-carrying conductors and, in particular, is proportional to their length. Hence, in such generators a high current gain ($k_T = (L_0/L_H)\eta$, L_H is the load inductance) is achieved due to the long length of the conductors, which leads to a high generator operating time of $\sim 100 \mu\text{sec}$.

The dimensions and operating time of plane-parallel explosive magnetic generators can be reduced severalfold by placing the busbars around a cylindrical conducting tube with the charge of explosive material along the axis. In [6] the operating time of the generator was reduced to $20 \mu\text{sec}$ in this way. The current-carrying conductors in this generator (a single-coil generator) had a constant cross section, which reduced η at the end of the generator operation, when the magnetic field strength reached a value higher than the critical value H_* for the conductor material (e.g., for copper conductors $H_* \sim 1 \text{ MOe}$ [1]).

The efficiency of a single-coil generator can be increased by shaping its current contour by a parabolic increase in the generating coil from the current terminal to the inductive load [7]. This form of variation of the generating winding is similar in form to the increase in the generator current and limits the increase in the linear current density $j_+(t) = \eta(t) \Phi_0 / L(t) z_+(t)$ (the magnetic field strength $H_+(t) = 0.4\pi j_+(t)$) along the line of dynamic contact of the envelope with the coil $z_+(t)$ while the generator is operating. By choosing the geometrical dimensions and the value of the initial magnetic flux of the generator Φ_0 , one can ensure the maximum permissible current mode of the conductors (with respect to the field value $H_+(t) \simeq 1 \text{ MOe}$), which is not exceeded during the operation of the generator at the stage of the electrical disruption of the skin surface of the conductors. This mode of operation is the most convenient for producing miniature explosive magnetic generators with specified electromagnetic parameters, viz., energy and power.

Moscow. Translated from *Zhurnal Prikladnoi Mekhaniki i Tekhnicheskoi Fiziki*, No. 5, pp. 66-73, September-October, 1978. Original article submitted September 9, 1977.

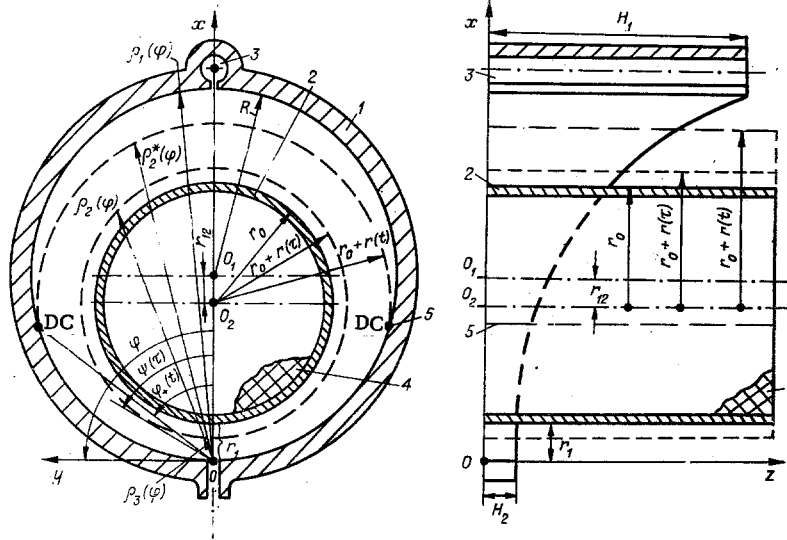

Fig. 1

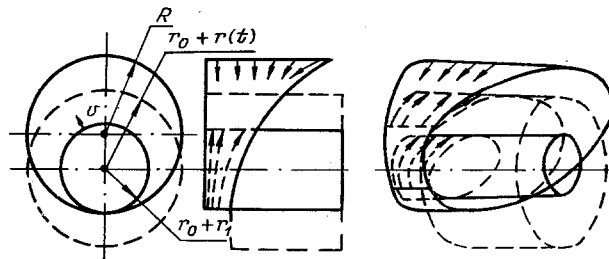

Fig. 2

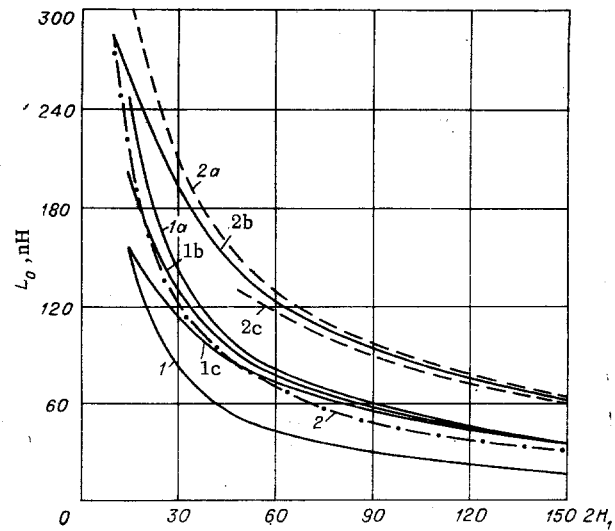

Fig. 3

The increase in the magnetic field in the generator (in the region of dynamic contact of the conductor) to a value $H_+(t) > H_*$ leads to intense surface heating of the conductors and to rupture of the surfacelayer, which increases the ohmic losses, and also facilitates the occurrence of intense local electrical breakdowns leading to cutting off of part of the magnetic flux in the dynamic contact region.

2. To determine the current mode of the conductors of the shaped coil of a magnetic-course generator and to investigate its advantages compared with existing explosive magnetic generators it is of interest to obtain the relationship between the inductance of the generator and the geometrical dimensions of its current contour.

A sketch of a single-coil explosive magnetic generator with a parabolic profile of the coil is shown in Fig. 1 (1 is the coil, 2 is the shell, 3 is the inductive load, 4 is the explosive charge, 5 is the length of the dynamic contact of the shell with the coil $z_+(t)$, R is the inner radius of the coil, r_0 is the outer radius of the shell, H_1 and H_2 are the maximum and minimum semigeneratrix of the windings, respectively; r_1 is the distance between the shell and the minimum generatrix of the coil, and r_{12} is the eccentricity). A polar system of coordinates (ρ, φ) is chosen in the transverse section of the generator with a pole at the lowest point 0 of the circle of radius r , and with the polar axis coinciding with the Ox axis.

The equations of the circle (the inner boundary of the coil) of radius R with center at the point $O_1(x=R, Y=0)$ and the outer boundary of the shell of radius $r_0+r(\tau)$ with center at the point $O_2(X=r_0+r_1, y=0)$ have the following form:

$$\begin{aligned} \rho_1(\varphi) &= 2R \cos \varphi, \quad 0 \leq \varphi \leq \pi/2; \\ \rho_2, s(\varphi) &= (r_0 + r_1) \cos \varphi \pm \sqrt{[r_0 + r(\tau)]^2 - (r_0 + r_1)^2 \sin^2 \varphi}, \\ &0 \leq \varphi \leq \pi/2, \end{aligned} \quad (2.1)$$

where $r(\tau) = \int_0^\tau v(\tau) d\tau$, $0 \leq r(\tau) \leq r_1$, $v(\tau)$ is the rate of expansion of the external boundary of the shell due to the products of the explosion and the back pressure of the magnetic field, τ is the instantaneous time of operation of the generator when the shell flies off to the minimum generatrix of the coil, $0 \leq \tau \leq \tau_k$, and τ_k is the instant when dynamic contact of the shell with the winding begins. To each instant of time τ there corresponds

sections of value φ bounded by the values $0 \leq \varphi \leq \psi(\tau)$ where $\psi(\tau) = \arcsin\left(\frac{r_0+r(\tau)}{r_0+r_1}\right)$ is the angle between the Ox axis and the tangent from the origin of coordinates O to the circle of radius $r_0+r(\tau)$.

When $t > \tau_k$ (t is the instantaneous time of operation of the generator, and $t - \tau_k$ is the instantaneous time of dynamic contact of the shell with the winding)

$$\begin{aligned} \rho_2^*(\varphi) &= (r_0 + r_1) \cos \varphi + \sqrt{[r_0 + r(t)]^2 - (r_0 + r_1)^2 \sin^2 \varphi}, \\ &0 \leq \varphi \leq \frac{\pi}{2}, \end{aligned} \quad (2.2)$$

where $r(t) = r_1 + \int_{\tau_k}^t v(t) dt$, $v(t)$ is the velocity of the shell at the stage of dynamic contact with the coil.

The canonical equation of a parabolic cylinder, the generatrix of which is perpendicular to the minimum generatrix of the coil and passes through it at the point $(x=0, y=0, z=H_2)$ has the form

$$2p(z - H_2) = x^2. \quad (2.3)$$

The boundary of the coil intersected by the parabolic cylinder and projected onto the xOz plane is also described by an equation of the form (2.3). The coefficient p of the parabola passing through the point $(x = 2R, z = H_1)$ follows from (2.3): $p = 2R^2/(H_1 - H_2)$.

Then any value of the coordinate z that varies from H_2 to H_1 is described by the equation

$$z(\rho, \varphi) = \frac{H_1 - H_2}{(2R)^2} (\rho \cos \varphi)^2 + H_2, \quad 0 \leq \varphi \leq \frac{\pi}{2}, \quad 0 \leq \rho \leq \rho_1. \quad (2.4)$$

From (2.4), using (2.1), we have the dependence of the change in the semigeneratrix of the coil

$$z(\rho_1, \varphi) = (H_1 - H_2) \cos^4 \varphi + H_2.$$

We will assume that the flow of the electric current over the shell with the explosive charge only occurs on that part of its surface which is bounded by the surface of the coil (Fig. 2, the region of current flow over the shell is shown by the dashed arrows and that over the coil is shown by the continuous arrows).

Then, for $\tau_k < t \leq t_k$ (t_k is the working time of the generator) using (2.2) we obtain from (2.4) the equation of the variation of the semigeneratrix of the surface of the shell over which the current flows

$$z(\rho_2^*, \varphi) = \frac{H_1 - H_2}{(2R)^2} (\rho_2^* \cos \varphi)^2 + H_2, \quad 0 \leq \varphi \leq \frac{\pi}{2}.$$

3. In the approximation of the uniform distribution of the magnetic field strength in the working cavity of the generator (the volume between the shell and the coil), i.e., when $\langle H_+(t) \frac{z(\rho_1, \varphi_+)}{z(\rho, \varphi)} \rangle = H$ the expression for the external inductance of the generator can be written in the form

$$L = \begin{cases} L(\psi(\tau)) + L_H, & 0 \leq \tau \leq \tau_k, \\ L(\varphi_+(t)) + L_H, & \tau_k < t \leq t_h, \end{cases} \quad (3.1)$$

where

$$L(\psi(\tau)) = 4\pi \cdot 10^{-9} \frac{S^2(\psi(\tau))}{V(\psi(\tau))} k_1(\tau); \quad L(\varphi_+(t)) = 4\pi \cdot 10^{-9} \frac{S^2(\varphi_+(t))}{V(\varphi_+(t))} k_1(t),$$

S and V are the area of the transverse section and the working volume between the radius of the shell $r_0 = r(\tau)$ (or $r_0 + r(t)$ at the dynamic contact stage) and the radius of the coil R , φ_+ is the coordinate of φ along the dy-

amic line, $k_1(\tau) \simeq \frac{1}{2} \left[f \left(\frac{r_1 - r(\tau)}{2H_2} \right) + f \left(\frac{\delta - r(\tau)}{2H_1} \right) \right] \leq 1$, $k_1(t) \simeq \frac{1}{2} \left[1 + f \left(\frac{\delta - r(t)}{2H_1} \right) \right] \leq 1$, $\delta = 2R - 2r_0 - r_1$ is the maximum base of flight of the shell. The nature of the variation and the numerical values of the function f are the same as for the function $f(b/h)$ (h is the width of the busbar and b is the gap between the busbars) for a current-carrying line of parallel plane plates [1].

At the stage when the shell flies off to the minimum generatrix of the coil ($0 \leq \tau \leq \tau_k$), we have

$$\begin{cases} S(\tau) = \pi [R^2 - (r_0 + r(\tau))^2], \\ V(\psi(\tau)) = 4 \left[\int_0^{\pi/2} \int_{\rho_2(\varphi)}^{\rho_1(\varphi)} z(\rho, \varphi) \rho d\rho d\varphi - \int_0^{\psi(\tau)} \int_{\rho_2(\varphi)}^{\rho_1(\varphi)} z(\rho, \varphi) \rho d\rho d\varphi \right]. \end{cases} \quad (3.2)$$

At the stage of dynamic contact of the shell with the coil $\tau_k < t \leq t_k$

$$\begin{cases} S(\varphi_+(t)) = 2 \int_0^{\varphi_+(t)} \int_{\rho_2(\varphi)}^{\rho_1(\varphi)} \rho d\rho d\varphi, \\ V(\varphi_+(t)) = 4 \int_0^{\varphi_+(t)} \int_{\rho_2(\varphi)}^{\rho_1(\varphi)} z(\rho, \varphi) \rho d\rho d\varphi. \end{cases} \quad (3.3)$$

Evaluation of integrals (3.2) and (3.3) leads to the following expressions, which enable the inductance (3.1) to be represented in the form of an explicit analytical dependence on the geometrical dimensions of the generator:

$$\begin{aligned} V(\tau) = & \frac{5}{8} \pi (H_1 - H_2) R^2 + 2\pi H_2 R^2 + \frac{3}{2} \pi \frac{H_1 - H_2}{R^2} (r_0 + \\ & + r(\tau))^4 - \frac{\pi}{2} \frac{H_1 - H_2}{R^2} \left[(r_0 + r_1)^2 (r_0 + r(\tau))^2 + (r_0 + r(\tau))^4 + \frac{4R^2 H_2}{H_1 - H_2} (r_0 + r(\tau))^2 \right], \end{aligned} \quad (3.4)$$

where

$$\begin{aligned} r_0 + r(\tau) = & (r_0 + r_1) \sin \psi(\tau); \quad \arcsin \left(\frac{r_0}{r_0 + r_1} \right) \leq \psi(\tau) \leq \frac{\pi}{2}; \\ S(\varphi_+(t)) = & R^2 (2\varphi_+(t) + \sin 2\varphi_+(t)) - \frac{1}{2} (r_0 + r_1)^2 \sin 2\varphi_+(t) - \\ & - \varphi_+(t) K^2(\varphi_+(t)) - (r_0 + r_1)^2 \left[\sin \varphi_+(t) \sqrt{a^2(t) - \sin^2 \varphi_+(t)} + a^2(t) \arcsin \left(\frac{\sin \varphi_+(t)}{a(t)} \right) \right], \end{aligned} \quad (3.5)$$

$$\begin{aligned}
V(\varphi_+(t)) = & (H_1 - H_2) \left[\frac{2}{3} R^2 - \frac{7}{24} \frac{(r_0 + r_1)^4}{R^2} \right] \cos^5 \varphi_+(t) \sin \varphi_+(t) + \\
& + (H_1 - H_2) \left[\frac{5}{6} R^2 + \frac{1}{96} \frac{(r_0 + r_1)^4}{R^2} - \frac{1}{2} \frac{(r_0 + r_1)^2 K^2(\varphi_+(t))}{R^2} \right] \times \\
& \times \left(\frac{3}{2} \varphi_+(t) + \sin 2\varphi_+(t) + \frac{1}{8} \sin 4\varphi_+(t) \right) + \left[4H_2 R^2 - \frac{1}{8} \frac{H_1 - H_2}{R^2} \times \right. \\
& \times K^4(\varphi_+(t)) + \frac{1}{4} \frac{H_1 - H_2}{R^2} K^2(\varphi_+(t))(r_0 + r_1)^2 \left. \right] \left(\varphi_+(t) + \frac{1}{2} \sin 2\varphi_+(t) \right) - \\
& - 2H_2 \varphi_+(t) K^2(\varphi_+(t)) - H_2 (r_0 + r_1)^2 \sin 2\varphi_+(t) - \frac{1}{24} \frac{H_1 - H_2}{R^2} (r_0 + r_1)^4 \times \\
& \times \sin^5 \varphi_+(t) \cos \varphi_+(t) - \frac{1}{96} \frac{H_1 - H_2}{R^2} (r_0 + r_1)^4 \left(\frac{3}{2} \varphi_+(t) - \sin 2\varphi_+(t) + \right. \\
& \left. + \frac{1}{8} \sin 4\varphi_+(t) \right) - (H_1 - H_2) \left[\frac{1}{8} \frac{(r_0 + r_1)^2 K^2(\varphi_+(t))}{R^2} + 2 \frac{H_2}{H_1 - H_2} (r_0 + r_1)^2 + \right. \\
& \left. + \frac{1}{2} \frac{(r_0 + r_1)^4}{R^2} \right] \left[\sin \varphi_+(t) \sqrt{a^2(t) - \sin^2 \varphi_+(t)} + a^2(t) \arcsin \left(\frac{\sin \varphi_+(t)}{a(t)} \right) \right] + \\
& + (H_1 - H_2) \left[\frac{1}{3} \frac{(r_0 + r_1)^4}{R^2} \sin^2 \varphi_+(t) - \frac{3}{4} \frac{(r_0 + r_1)^4}{R^2} \right] \sin \varphi_+(t) \sqrt{(a^2(t) - \sin^2 \varphi_+(t))^3},
\end{aligned}$$

where

$$a(t) = K(\varphi_+(t))/(r_0 + r_1); \quad K(\varphi_+(t)) = r_0 + r(t) = \sqrt{R^2 + (R - r_0 - r_1)^2 + 2R(R - r_0 - r_1) \cos 2\varphi_+(t)}, \quad 0 \leq \varphi_+(t) \leq \pi/2.$$

In particular, to calculate the initial inductance of the generator, we put $\tau=0$ in (3.2) and (3.4), and thereby obtain

$$\begin{aligned}
S(0) &= \pi (R^2 - r_0^2), \\
V(0) &= \frac{5}{8} \pi (H_1 - H_2) R^2 + 2\pi H_2 R^2 + \frac{3}{8} \pi \frac{H_1 - H_2}{R^2} r_0^4 - \frac{\pi}{2} \frac{H_1 - H_2}{R^2} \left[(r_0 + r_1)^2 r_0^2 + r_0^4 + \frac{4H_2 R^2 r_0^2}{H_1 - H_2} \right], \\
k_1(0) &\simeq \frac{1}{2} \left[f\left(\frac{r_1}{2H_2}\right) + f\left(\frac{\delta}{2H_1}\right) \right] \leq 1.
\end{aligned}$$

The change in the inductance of a single-coil generator with a constant generatrix of the coil (h) is given by the expression

$$L = 4\pi \cdot 10^{-9} k_1 S/h + L_H,$$

where the value of S at the corresponding stage of operation of the generator is equal to $S(\tau)$, as given by (3.2), or $S(t)$, as given by (3.5),

$$k_1(\tau) \simeq \frac{1}{2} \left[f\left(\frac{r_1 - r(\tau)}{h}\right) + f\left(\frac{\delta - r(\tau)}{h}\right) \right] \leq 1, \quad k_1(t) \simeq \frac{1}{2} \left[1 + f\left(\frac{\delta - r(t)}{h}\right) \right] \leq 1.$$

4. The initial inductance of the shaped coil generator depends on the relative position of the core and the coil. The value of inductance (3.1) increases as the shell is moved from the minimum generatrix of the coil towards the inductive load (due to the reduction in $V(0)$). The operating time of the generator in this case decreases (due to the reduction of δ). This suggests it is worth carrying out the above displacement both to reduce the operating time of the generator and to increase the rate of variation of the inductance. However, when such a displacement is made, the value of the coefficient $k_1(0)$ decreases for small values of the generatrix of the coil $2H_1$ and $2H_2$ (as occurs in a generator with dimensions $2H_1=15$ cm, $2H_2=1.5-2$ cm, $2R=19.1$ cm, $2r_0=13.1$ cm, $\delta=5$ cm). The initial inductance does not increase as the value of displacement r_1 is increased (Table 1).

For similar values of the displacement in the generator ($2H_1=150$ cm, $2H_2=15$ cm, $2R=19.1$ cm, $2r_0=13.1$ cm, and $\delta=5$ cm), with the same transverse dimensions of the coil and the shell but with larger values of the generatrix, the initial inductance increases due to the reduction in the edge effect (Table 2).

Figure 3 shows the results of a calculation of the initial inductance of shaped and unshaped generators with the same transverse cross section of the coils and shells, and with the same relative positions. The dimensions of the generators are shown in Table 3. Curve 1 shows the inductance of an unshaped generator (with a diameter of the explosive charge of 20 cm) as a function of the value of the coil generatrix. Curves 1a-c show the inductance of a shaped generator ($2r_{\text{exp}}=20$ cm) as a function of the maximum generatrix of the coil for a number of values of the minimum generatrix (curves 1a-c correspond to value of the minimum generatrix of 2, 8, and 15 cm). Curves 2 and 2a-c are for generators with an explosive charge diameter of 12.5 cm.

TABLE 1

r_1 , cm	$k_1(0)^*$	L_0 , nH	$t_{k_1}^\ddagger$, μsec	$k_1(\tau_k)$	$\tau_{k_1}^\ddagger$, μsec
0	0,875	209,04	24	—	—
0,5	0,738	181,2	22	0,876	2
1,0	0,7	177,14 (167) †	21	0,89	5
1,5	0,665	174	19,5	0,9	7,5
2,0	0,635	172,37	18	0,93	10
2,5	0,6	169,6	16,5	1,0	12,5

* The values of the coefficient k_1 are obtained using the data in [1].

† A laboratory measurement on a model of a generator of conducting foil.

‡ The instants of time are obtained from the values of velocity $v(t) = \text{const} = 0.2 \text{ cm}/\mu\text{sec}$ and $v(t) = \text{const} = 0.25 \text{ cm}/\mu\text{sec}$, close to the experimental values.

TABLE 2

r_1 , cm	$k_1(0)$	L_0 , nH	t_{k_1} , μsec
0	1	16,07	24
0,5	1	25,47	22
1,0	0,98	25,86	21
1,5	0,95	25,92	19,5
2,0	0,925	26,26	18
2,5	0,913	27,08	16,5

* The increase in the value of the displacement r_1 from 0 to 2.5 cm is equivalent to a reduction in the eccentricity of the shell and the coil from 3 to 0.5 cm.

TABLE 3

No. of wave	Type of generator	R, cm	r_0	r_1	δ	r_{exp}	$2H_1$
1	Unshaped	13,3	10,3	1	5	10	$2H_1$
1a	Shaped	13,3	10,3	1	5	10	2
1b	"	13,3	10,3	1	5	10	8
1c	"	13,3	10,3	1	5	10	15
2	Unshaped	12,9	7,15	3,5	8	6,25	$2H_1$
2a	Shaped	12,9	7,15	3,5	8	6,25	5
2b	"	12,9	7,15	3,5	8	6,25	10
2c	"	12,9	7,15	3,5	8	6,25	15

It follows from a comparison of a curve that for the same dimensions of the coil generators the inductance of a shaped generator is approximately twice as great as that of an unshaped generator. The rates of variation of the inductance of the generators at each instant of the time of operation are found to be in the same ratio, as well as the final values of the current gain ($k_T = (L_0/L_H)\eta$) and the energy ($k_e = k_T \eta$) in the part which depends on L_0 .

The calculated values of the inductance agree well with experimental data. Thus, for a generator with dimensions ($2H_1 = 18$ cm, $2H_2 = 4$ cm, $2r_0 = 14$ cm, $2R = 24.3$ cm, $\delta = 6.8$ cm, and $r_1 = 3.5$ cm) the theoretical value of the initial inductance is 215 nH while the experimental value is 212 nH.

LITERATURE CITED

1. H. Knopfel, *Superintense Pulsed Magnetic Fields* [Russian translation], Mir, Moscow (1972).
2. A. D. Sakharov et al., "Magnetic cumulation," *Dokl. Akad. Nauk SSSR*, **65**, No. 1 (1965).
3. E. I. Bichenkov et al., "Experiments on an explosive magnetic generator under laboratory conditions," *Dokl. Akad. Nauk SSSR*, **183**, No. 6 (1968).
4. E. I. Bichenkov, "Explosive generators," *Dokl. Akad. Nauk SSSR*, **174**, No. 4 (1967).
5. H. Knopfel et al., "The generation and switching of magnetic energies in the megajoule range by explosive systems," *Frascati, Italy* (1968).
6. S. J. Lubasik, G. W. Zepko, and R. L. Jameson, "Magnetic flux compression in an explosion geometry," *Proceedings of the Conference of Megagauss Magnetic Field Generation by Explosives and Related Experiments, Frascati, Italy* (1965). *Brussels Eur. Atom*, 397-419 (1966).
7. A. Ya. Koshelev, V. S. Fomenko, and V. I. Chizhov, "An explosive magnetic current generator," *Byull. Izobret.*, No. 33, 178 (1974).